



### Features /

- ◆ 12VDC power input, can be combined with security/ burglar system
- ◆ Relay contact : N/C (normal/close) N/O (normal/open) alternative.
- ◆ With a button on the surface, when detector sense the smoke, the LED light up until press the button to reset.

### Sensing way /

Optical smoke detector responds to smoke. It has a chamber inside consists of a "light-emitting diode (LED)" that constantly shoots a beam of light and a "photocell" that senses light from darkness. In peacetime, the "photocell" can not senses the beam of light form the "light-emitting diode (LED)". When there is smoke into the chamber of detector ,the beam of light is scattered by smoke particles, and the scattered light hit the"photocell", thus the alarm is initiated.

### Specifications /

Model No	FMD-602-12V	Overall structure	
Input Voltage	12VDC	Material	Fire-resisting ABS material
Standby current	60 $\mu$ A	Joint contact	Copper (zinc-plated)
Alarm current	50mA	Color	Ivory
Suitable temperature	-15~50° C	<b>Notes</b> Prohibit from being installed at the places with large volume of smoke and steam lingering, and the inlet and outlet of cold and warm air.	
Suitable humidity	0~95% RH		
Size	103mm x 43mm		
Weight	150g		
Relay contact volume : DC 3~30V , 1A AC 100~220V , 1A			

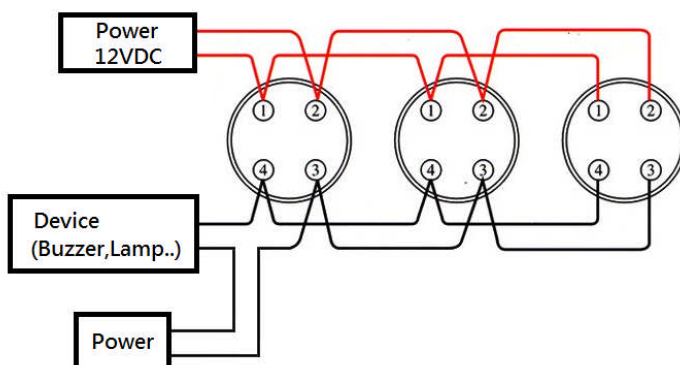

- ◆ The red wires are the power source (12VDC) for detector.
- ◆ The black wires connect to the device to be driven.
- ◆ point 3 and point 4 are relay contact: 1A (NO or NC alternative)