



Hand-held Parameter Controller for the WAT-260S

Active Visual Mate



WAT-260S

Active Visual Mate is specifically designed for use with the WAT-260S.

■ Concept

- To improve and extend the usage of the **WAT-260S**
- To refine the **WAT-260S** into a more precise research tool
- To create a convenient and versatile **WAT-260S** by integrating **Active Visual Mate**

Watec

Watec Co., Ltd.
254-2 Nihonkoku, Daihoji, Tsuruoka-Shi, Yamagata-Ken, 997-0017, Japan
TEL : +81-235-25-7164 FAX : +81-235-23-4409
E-mail : info-o@watec.co.jp URL : <http://www.watec.net>

Hand-held Parameter Controller for the WAT-260S

Active Visual Mate

■ Functions

- ◆ AE mode control :
 - Gain : 2 settings
 1. Selectable AGC range from 6 to 30dB in 1dB steps
 2. Manual fixed gain selectable from 6 to 30dB in 1dB steps
 - Shutter speed : 2 settings
 1. EI (Minimum and maximum shutter speed range can be selected manually from OFF to 1/100000 (OFF (1/60(N) or 1/50(P)), FL (120(N) or 1/100(P)), 1/250, 1/500, 1/1000, 1/2500, 1/5000, 1/10000, 1/20000, 1/50000, 1/100000.)
 2. ES (Shutter speed can be selected manually from the above mentioned 11 settings.)
 - Back light compensation : 5 selectable area settings
 - Setup level control : control within a range of 0 to 50mV (7.5 IRE)
 - Video level selection : select either 75 IRE or 100 IRE
- ◆ White balance control : 2 settings
 1. ATW
 2. Fixed (Color temperature can be selected from 3200K, 4400K, 5100K, and 8200K. RED and BLUE gain can be finely adjusted separately.)
- ◆ NTSC/PAL auto-select
- ◆ Gamma correction : select either 0.45 or OFF
- ◆ Outline enhancer : both horizontal and vertical in 5 steps
- ◆ Color selection : select either Color or Monochrome
- ◆ Mirror image function
- ◆ Data save/delete function

■ Specifications

- ◆ Power supply : DC6V \pm 10%
Use the "AD-603" power adapter or dry cell batteries AA (×4).
- ◆ Current : about 50mA (with display back light "ON")
- ◆ Weight : 330g
- ◆ Accessory : cable (1m)

■ Dimensions (mm)

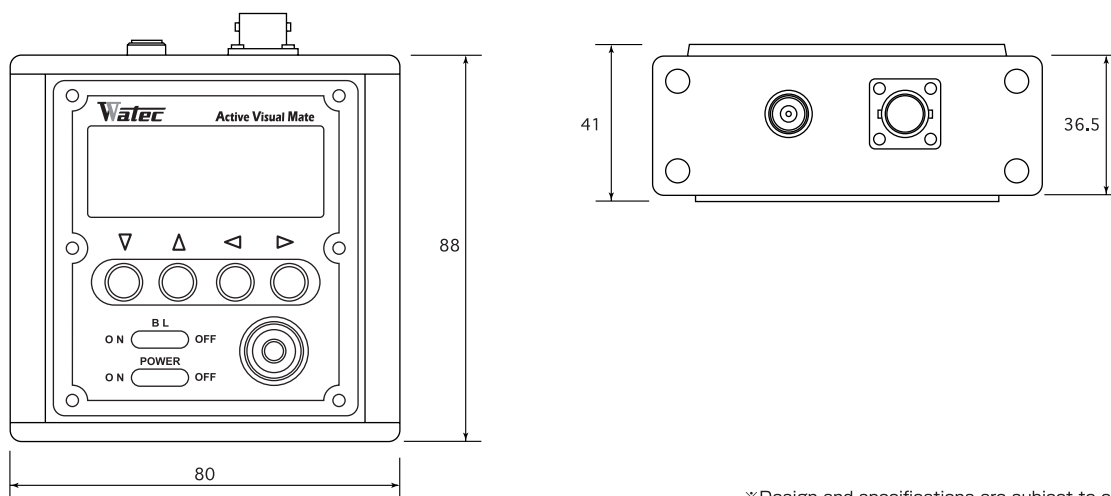

※Design and specifications are subject to change without notice.

Watec

Watec Co., Ltd.

254-2 Nihonkoku, Daihoji, Tsuruoka-Shi, Yamagata-Ken, 997-0017, Japan

TEL : +81-235-25-7164 FAX : +81-235-23-4409

E-mail : info-o@watec.co.jp URL : <http://www.watec.net>